

EXECUTIVE DIRECTIVE

SO ED 2104 INT

7 November 1982

CO/EDs ALL ORGs
MISSION HOLDERS ALL MISSIONS
SNI WW
SNI INT
FOLOS
IMO
EXEC STRATA
WDC

THE FLOW UP THE BRIDGETHE US MISSION HOLDERS CONFERENCESAN FRANCISCO 1982

Attached you will find the transcript of the US Mission Holders' Conference held in San Francisco on 17 October 1982.

The purpose of the convention was for top officials of the Sea Organization to brief the US Mission Holders on the role of the Mission Network and the need for the missions to function in a coordinated way with the other Scientology organizations to achieve a common purpose of getting people up the Bridge and Clearing the planet.

Specifically covered in the transcript are the exact legal and ecclesiastical boundaries within which the missions operate.

The role and the power of the owner of the trademarks of Dianetics and Scientology, the Religious Technology Centre, is clearly laid out in the attached transcript.

This is vital information for all missions and orgs.

The new corporate structure of the Church that is the legal guarantee that Scientology will expand infinitely is also laid out in detail in this transcript.

The flow of the public up the Bridge has been inadequate.

The purpose of the convention (and of sending you this transcript) is so a full understanding is achieved of the proper flow up the Bridge and of responsibilities and duties of each echelon in actually flowing public up that Bridge in volume.

The missions are the entrance point of the Bridge. Their responsibility is the disseminating of Dianetics and Scientology to raw public and then flowing that public up the Bridge to orgs. This responsibility is of great importance for this planet and that responsibility must be taken.

Read the transcript.

It contains absolutely vital information that you cannot afford to ignore.

Capt. Guillaume Lesevre
ED INTERNATIONAL

Authorized by
AVC INT

SEE THE
CHURCH OF SCIENTOLOGY
INTERNATIONAL

CSI:AVCI GL:1w

CMDR. DAVID
MISCAVIGE:

We're going to be briefing you on several changes that have occurred within the Church in the last nine months; legally and corporately as well as organizationally.

This briefing pertains to how these changes apply to you. The first thing you're going to hear about is trademarks and copyrights; what they're all about and how they apply to you. First person I'm going to introduce is an Attorney, his name is Larry Heller and he is going to explain this to you. Mr. Heller?

(Clapping.)

AUDIENCE:

LARRY HELLER,
CHURCH ATTORNEY:

Most of you are probably familiar with what a trademark is but perhaps, for our purposes, a small explanation might be in order.

A trademark is a symbol which is held out to the public representing to that public a certain quality of product or service which, when the public buys under that trademark, it's assured of getting. To give you a very simple example. Some of you might have had a glass or a bottle of Coca-Cola with your lunch today. Hypothetically, one or two of you might be in Hong Kong tomorrow and have a bottle of Coca-Cola with your lunch as well. That Coke is going to taste exactly the same tomorrow when you get to Hong Kong as the bottle of Coke that you opened up today. As long as it has that Coca-Cola symbol on it, comes in that very distinctive bottle; that means that you're going to get a certain mixture of ingredients, a certain effervescence.

Scientology, as all of you know, also has trademarks. Most of you are familiar with what those trademarks are. They relate to Dianetics, they relate to Scientology, they relate to L. Ron Hubbard. Those trademarks, just like the Coca-Cola trademarks, represents a symbol which assures the public of a certain quality of service which they are going to receive if they purchase something or receive services under that trademark.

All of the Scientology/Dianetic trademarks were previously owned by L. Ron Hubbard. L. Ron Hubbard has donated the vast majority of those trademarks, some of you have probably heard of, by the name of Religious Technology Center. In donating those trademarks, L. Ron Hubbard imposed the duty on Religious Technology Center (RTC) of assuring that the source of those trademarks, the technology that those trademarks represent, are given and disseminated to the public in the way that he formulated those trademarks. It's what you know as being on Source, applying tech. The duty imposed upon RTC to properly police those trademarks, to assure that Source is applied in their use by anyone to whom RTC sub-licenses them, is not only a very heavy spiritual burden but is, as well, a great legal duty. RTC is legally under a duty to assure that anyone it permits to use these trademarks utilizes them according to Source as formulated by L. Ron Hubbard.

RTC, in turn (Religious Technology Center is known as RTC in short) licenses those trademarks at its will through a sub-license to the Church of Scientology International. Church of Scientology International is responsible for disseminating those trademarks to different organizations within the umbrella of the Church of Scientology. One of those organizations is SMI: Scientology Missions International. They in turn, give you the right to use those trademarks.

Now, even though RTC licensed them through CSI and licensed them through, in your instance, SMI, down to you; RTC has the duty and is bound, not only in an ecclesiastical sense but in a very important legal and corporate sense, to make sure that those trademarks are utilized properly, that Source is applied. Consequently in the licensing agreements through which those trademarks are disseminated to CSI, and then through SMI, to you, there are enforcement procedures which may be utilized to assure that RTC fulfills its duty to L. Ron Hubbard through a policing of those trademarks. Let me explain to you what those enforcement procedures are.

RTC has a right to send a mission directly to the individual mission holders to determine whether the trademarks are being properly used by you. This mission may review your books, your records, and interview your personnel. No matter what determination RTC makes respecting the proper use of the trademarks entrusted to you it can get reimbursed from you, the individual mission holder, for the mission that was sent to investigate your use of the trademark.

If there's a determination by RTC that Scientology services being given to public by any of you under the "Scientology" trademarks are not on Source then RTC, either directly or through CSI and SMI, has the right to immediately suspend any utilization by the individual missions of those trademarks. The word "immediate" is the key word here. There need not be, at this point, a hearing in order for there to be a suspension. RTC will order that you no longer use the trademark and you must stop or be subject to civil penalties and ultimately, criminal prosecution.

The reason for the immediate suspension is so there cannot be a dissemination of these services in a wrongful manner. In a manner that L. Ron Hubbard did not mean them to be utilized and disseminated. At some point after this immediate suspension occurs, there may be an arbitration. The arbitrator or arbitrators who will hear the matter are members in good standing of the Church of Scientology and are specifically members of the Church of Scientology International. There is a determination made at that arbitration whether the trademarks were utilized by you in accordance with Source. If in fact the trademarks were not used according to the Source, the suspension which has taken place becomes permanent.

If there is a suspension after that arbitration, that award suspending your use of the trademark will be taken into a court of law. It will there be made into a lawful judgement of that United States Court. An infringement upon that judgement, specifically the use of the particular trademarks after they've been withdrawn from you subjects you to civil and criminal liability. You may be liable for contempt of court. Disobeying a court order. Violation of that court order suspending or withdrawing use by the mission of that trademark, becomes punishable by the imposition of a fine or a jail sentence.

If there should thereafter be a continuation by you of any Scientology trademarks, application will be made to the District Attorney or whatever legal official is empowered to prosecute criminal acts resulting in a possible criminal conviction for an unfair business practice. You will then be fined or thrown into jail.

As an aside, this would also be true if a previously unlicensed person or corporation continued to use the trademarks after being told to cease and desist by RTC; the rightful trademark owner. It is also true that using the materials of Dianetics and Scientology but calling it something else is actionable under criminal law as a violation of trademarks and copyrights.

My law firm has been instructed to make sure that if there is in fact an unauthorized use of any of these trademarks, if it is determined that the mark was not used in accordance with Source, that we enforce ETC's rights which I've just described to you, throughout the judicial procedure to get a Superior Court or US Court judgement and then enforce that judgement through contempt and criminal proceedings.

Thank you.

(Clapping.)

Scientology will go as far as it works, and when it is not applied correctly (out-tech), that's a violation of trademarks. This is a very serious matter.

Earlier this evening both Kingsley Wimbush and Dean Stokes were here. They have both now been declared, and we are pursuing criminal charges against them. They have both been delivering their own squirrel tech, while calling it Scientology. Kingsley Wimbush's "dinging process" is completely squirrel. You won't find it in any tech, yet he has been calling it Scientology. That's a violation of trademark laws and he now faces some serious charges for this crime. This sort of activity is NOT going to go on anymore.

Next person who I am going to introduce to you is Warrant Officer Lyman Spurlock. He is the Corporate Affairs Director and he is going to brief you on the new Corporate structure of the Church.

AUDIENCE:

CMDR. DAVID
MISCAVIGE:

WARRANT OFFICER
 LYMAN SPURLOCK,
 CORPORATE AFFAIRS
 DIRECTOR:

AUDIENCE:

WARRANT OFFICER
 LYMAN SPURLOCK:

I'm going to give you a chalk talk here.
 Everybody hear me in back?

Yeah.

Okay. Prior to the end of 1981, a few of us got together and took a look at the corporate structure of the Church with the view in mind of making it more defensible and more regular, and to make an overall improvement. Here's how it looked roughly before the end of 1981 (Chart 1). We had this one huge corporation known as Church of Scientology of California, CSC. Within the Church of Scientology of California, there were numerous org entities. There was WDC, CMO Int, there was ED Int, there was the Exec Strata, there was FSO, there were AOLA, ASHO, LA Org, San Francisco Org, POLO WUS, there was the Cadet Org, there was the US GO. I've run out of space but I haven't run out of orgs.

The problem with this is here we have all of these organizations within this one giant corporation functioning as different corporations and the money flows and the policy flows, etc. look like there's a whole bunch of corporations dealing with each other and this whole spaghetti that somebody, someone comes in and takes a look at this and they go, "what the hell is this?" They couldn't understand it. Further, as you can see they are divided into distinct geographical locations. We have some of it in L.A., we have some of it in Clearwater, in the earlier years prior to being in Clearwater, it was off on a ship and we have some in San Francisco. Didn't make a lot of sense. CSC also represented itself as a Mother Church.

Just to show you how crazy it was, we had another Mother Church, or at least it called itself the Mother Church and that was WW and that was in a corporation known as Religious Education College in the UK. Actually an Australian corporation registered to do business in the UK.

Now, underneath the CSC the Mother Church, we have all the orgs. They ran the orgs.

Also the most prosperous units in Scientology were in C of S of C. The FSO, ASHO and AOLA to name three. Now under WW we have the Mission Network. Kind of a schizophrenic lineup. We have two Mother Churches, two different corporations and this corporation was completely out of control in terms of size.

I'll let you in on a little secret as to why this happened. It wasn't by accident, it was by design.

Bob Thomas, when he was DG US had his personal motives, he was going to take over the Church. He figured, Oh, I'll lump everything together in this one corporation and I'll set myself up as

WARRANT OFFICER:
 LYMAN SPURLOCK
 (cont'd):

head of this corporation. Then I'll take over, for my own personal gain. It was not the best intentioned plan.

So, in late 1981 we took a look at this and said, this can't go on; it's not very defensible, it doesn't make sense. Let's line it up as the Church hierarchy is lined up. So what we did is we split up C of S of C and we reorganized WW in the following manner (Chart 2). WDC, CMO Int, ED Int and the Exec Strata were put into a new corporation known as Church of Scientology International. The FSO was broken into a separate corporation; San Francisco Org was broken into a separate corporation and L.A. Org was broken into a separate corporation, which I'm not going to show here because they all fall under the heading of orgs. Okay. They are managed either directly by the Church of Scientology International, in the case of the FSO or through the FOLO line.

C of S of C now consists of AOLA and ASHO as their major delivery orgs. It also has Golden Era Studios, FOLO WUS, the Cadet Org and the USGO in it, okay. But that also falls under orgs.

We also set up a new corporation to manage missions and this is Church of Scientology Missions International, okay. You notice I put it under CSI? The reason I put it under Church of Scientology International is Church of Scientology International is the ecclesiastical head of the Church. That is the top of the ecclesiastical hierarchy. That is the Mother Church. Scientology Missions International is another Church corporation. It's a unique Church corporation in that it is designed to manage missions. So here's corporately how the authority flows. It flows from Church of Scientology International to SMI to the missions. Now it is the intention that Scientology Missions International will manage the Mission Network and will wear its hat and Church of Scientology International will manage the orgs. SMI will receive, from time to time, guidance and strategic planning from Church of Scientology International, okay?

Now along with this set-up, as Mr. Heller just mentioned, we formed a new corporation to hold the trademarks of Scientology. Trademarks of Scientology, by the way, are the words, "Dianetics", "Scientology", the S and double triangle, the name "L. Ron Hubbard", the signature "L. Ron Hubbard", the initials "LRH", the 8 pointed cross, the Sea Org symbol -- those are all registered trademarks, okay. Now where do we position RTC, Religious Technology Center. Its actual formal name is Religious Technology Center. It is a Church corporation, okay. ←

It's up above. Why is it up above? It's up above not because it's a management unit but because it owns the trademarks. It has authority over any echelon in Scientology that is delivering services under the marks. Okay, and this

WARRANT OFFICER
 LYMAN SPURLOCK
 (cont'd):

does not just include down to the mission level, it will include the Field Auditors very shortly. It does include the Field Auditors now, we're about to license them.

There is no more such thing as MOWW. It no longer exists. Every mission is a SMI mission. Just to take any confusion out of that.

Another thing that's happening is that missions... once before it was kind of loosey-goosey. Missions could be a sole proprietorship. You reported on something called the schedule C of your tax return or it could have been a partnership or something like that.

From now on all missions will be corporations. There's very good reasons for this. A lot of you may know that you just recently received new corporate papers, let's see some nods, okay. These new corporate papers are designed to make the whole structure impregnable, especially as regards to the IRS. Have any of you read the religious language in these corporate papers? Okay. Before we came along and did this overhaul, you couldn't tell whether you were dealing with a 7 Eleven store or Church of Scientology from corporate papers because the purposes as expressed in the corporate papers were purely commercial. One of the reasons that society doesn't understand us or hasn't understood us as well as they should have in the past is because haven't really communicated what we are along the proper lines. Well those corporate papers are the proper legal communication of what is this entity, a mission of the Church of Scientology. It's actually an incorporated Church. It's like any other Church and Scientology is aligned as a Church hierarchy as is almost every other successful religion is. There's no religion that has ever been successful on the basis of anarchy. They're all ecclesiastical hierarchies receiving their guidance from a central point. Okay, the central point in terms of ecclesiastical guidance is CSI. The protector of the religion is RTC. RTC is charged with the responsibility of seeing that Scientology is kept standard. You know, when you talk about trademark standards, it's very easy to know what's meant. It's what's written down in the scriptures. The scriptures being defined as the recorded and written words of L. Ron Hubbard with regard to the technology of Dianetics and Scientology and the organizations. The organizational tech as well as the auditing tech is included in the definition of the scriptures.

Now RTC is a very formidable group of Sea Org members who have the toughness to see that the tech is standardly applied. LRH, seeing this new corporate structure, having a group of people in RTC that he had confidence in, donated the trademarks. Up to the point of May of this year it was always LRH who would step in and save the day as the trademark owner. Now he's entrusted this group of people to carry on that function and that's how the new corporate line-up is.

WARRANT OFFICER
LYMAN SPURLOCK
(cont'd):

I'm going to turn this over back over to Mr. Miscavige.

AUDIENCE:

(Clapping.)

CMDR. DAVID
MISCAVIGE:

There's a couple of reasons we wanted you to know about that. One is so you saw where your mission fit into the entire corporate structure of the Church and number two is, so that you could see how the Church has been corporately reorganized and that it really is impregnable. It will be around forever. The corporate structure assures Scientology being around for eternity.

Next person I'm going to introduce to you is, Commander, Steve Marlowe, and he is an Inspector General from the Religious Technology Center and he is going to brief you a little bit more on RTC and the function he is going to be doing.

AUDIENCE:

(Clapping.)

CMDR. STEVE
MARLOWE, INSPECTOR
GENERAL from the
RELIGIOUS TECHNOLOGY
CENTER:

Thank you. The gentlemen that have talked thus far have majorly given examples of out-tech. If you apply the tech non-standardly, you are subject to what could possibly be severe ramifications by the Religious Technology Center. If you are applying it standardly, you have the full support of the Religious Technology Center and the protection by the Religious Technology Center. Is that very clear?

AUDIENCE:

Yes.

CMDR. STEVE
MARLOWE:

And it is not based on personalities, it is not based on politics. We are a religion and this religion is what is going to save mankind. Get the idea? 30 years from now, someone squirms Scientology and starts calling it Scientology because there's a lot of money to be made, he says to himself before he falls asleep each night. Suddenly you have factions, schisms, all kinds of very horrible things -- they will never occur to this Church, never. They have not and they will not, the corporate structure that Mr. Spurlock has just shown you ensures that totally. The fact of the matter is you have a new breed of management in the Church. They're tough, they're ruthless, they are on Source. They are people that you can look up to and know that they are going to be there and that they are going to make sure that we get this job done. They don't get muscled around by crazy loonies, they don't get muscled around by people who are squirrelling, none of that. On this team you're playing with the winning team, totally and utterly. We have salvaged the legal scene, we have salvaged the corporate scene, we have brought the Church together and that's what this management is doing. It's tough, it's ruthless, it's on Source, just like you are expected to be.

CMDR. STEVE
MARLOWE
(cont'd):

Now quite aside from how are we going to apply "R3RA", you also have other technologies in Scientology. Policy Letters. Policy Letters on how one runs organizations. This is also a subject where breach of trademarks can occur. It also gets into other possible legal breaches. I'm sure you've read the paper in the last 6 months where various Japanese corporations were sneaking people into United States corporations and stealing computer designs, this sort of thing. That's called Industrial Espionage and Sabotage. Unfortunately some individuals thought it okay for this to happen within our Church. Let's say that you were the Publisher for a big magazine and one of your sales person gave your mailing list away to another magazine, what would you call that? I mean is that like share the wealth or what? No, it's a crime which will get one in jail.

No way. That does not go down. It also, in our case violates very strong Scientology policies. Rip-offs of orgs will not be tolerated, orgs do not supply anyone their mailing list. The days of taking the Org's PES O/O out to dinner and casually nipping off 20 or 30 names is ended. Holding onto upper level students and preclears when they should be moving up the bridge, which is exactly what we're here for, are over. They are violations of long standing policy. You will be receiving more specific information regarding those sort of subjects.

They enter into such criminal or civil charges as conversion, theft, not to mention Industrial Espionage and Sabotage which will get you 2 years in the pokey.

In the years that we have been operating, many many times people have been labelled and declared suppressive, heads on pikes, conditions assigned, rights taken away from an ecclesiastical point of view. However, now such persons will actually be prosecuted quite in addition to any Church justice procedure warranted when actual crimes, such as those mentioned above, are found.

The fellow (Bob Thomas) who made a mish-mash of the Church had previously been declared Criminal cancelled the declare and then he even went to the Flagship. Back on lines again. Did you know that when Bob Thomas came to the Mission Holder Convention last year, he said one thing; "I'm here to ensure that everything about the Church's finances are in order, and see how I can get in on them!" He's a suppressive and he has never had the intention of forwarding our religion. But only his money motivated pockets. At times you hear about various factions outside the Church, you know what factions are? They're areas that splinter off under some sort of pretended "OL". Nattering about management... That "they're big, bad meanies" or, "we don't like the direction they're giving us" or ya, ya, yip yap. Those days are over. Specific policy letters cover it. Discontent and

CMDR. STEVE
MARLOWE
(cont'd):

malcontent. There are always ways to get your grievances handled. And those who ignore standard lines are always found to have overta of magnitude against those they natter about.

Regardless, they're over because this management means business. There are ecclesiastical concerns, there are secular concerns. Violations will be prosecuted without a doubt. And we're just not here to threaten you or whatever. This is your salvation too. You just take a look at the viewpoint that someone would have behind bars looking out at the rest of Scientology. Not too sweet. We're not going to get stepped on.

If you're on our team you're on the winning team, on-Source, ruthless and tough.

The Inspector General Network exists within RTC. They have tremendous information lines. They have resources that enable them to get down to the very lowest echelon of the field. And quite frankly things will get found out about. So it's a matter of applying the technology exactly, staying on the straight and narrow. Understanding what your purposes are as Scientologists and Mission Holders. If you know what your purpose is then you will be flying right.

I just wanted to expound a bit on "dinging". Raise your hand if you've ever read an HCOB where L. Ron Hubbard uses the word "ding". (long pause) Of course not! There is no such thing as "dinging" or "de-dinging". NONE! If you follow those you are subject to the same penalties that will apply to the originator. The only workable Technology is real Scientology. Not Kingsley's brand or anyone else's.

If you follow the tech by L. Ron Hubbard exactly and standardly you will receive the protection of the Religious Technology Center by way of ensuring that squirrels are not encroaching upon your area or your spheres which can mean one hell of a lot. Okay? Thank you.

(Applause.)

Thank you Mr. Marlowe.

I hope that gave you some reality on RTC and the Inspector General Network.

To recap on one point. The Inspector General Network will not only be assuring the 100% standard application of Dianetics and Scientology Technology, both Red on White and Green on White. But they will also be quite aware of any criminal actions which may go in within the Church from any sort of outside sources. Stealing an org's mailing list (a separate corporation) or bribing a staff member to give the list to you, or give you org prospects or org pcs and students is a crime in any court of the land.

AUDIENCE:

CMDR. DAVID
MISCAVIG:

CMDR. DAVID
MISCAVIGE
(cont'd):

We are not outside the law and we are not a bunch of outlaws. It appears that persons thought that they could commit criminal acts and that they were outside the law. That they were lucky because they would only be dealt with the sane Justice Procedures of the Church. Well, rip-offs of mailing lists and that sort are prosecutable in any criminal court, and 2 years behind bars is what criminals guilty of such acts have to look forward to. We have a planet to clear and the person interested in his own backpocket over and above the application of Scientology so as to save this planet will be dealt with severely and no one will have to worry any longer about our progress being impeded by that sort of person.

The next person I want to introduce to you is Commander Norman Starkey. He is a veteran Sea Org member and will brief you in regards to some separate legal matters.

Mr. Starkey.

AUDIENCE:

(Applause.)

CMDR. (RA) NORMAN
STARKEY:

How are you all doing?

AUDIENCE:

(All right, etc.)

CMDR. (RA) NORMAN
STARKEY:

You all know my name. There's a couple of names I don't know. What's your name with the beard?

PERSON:

Jim (inaudible).

CMDR. (RA) NORMAN
STARKEY:

Where are you from?

PERSON:

Stevens Creek Mission.

CMDR. (RA) NORMAN
STARKEY:

Ah, OK, good. And the other one.

PERSON:

(Says name.)

CMDR. (RA) NORMAN
STARKEY:

Jim?

PERSON:

(Darcy.)

CMDR. (RA) NORMAN
STARKEY:

Darcy. Where are you from?

PERSON:

Berkeley.

CMDR. (RA) NORMAN
STARKEY:

Berkeley, okay, good. I just noticed you looked a little frowning most of the time here. Maybe you're unhappy about some of the things that have been said or a little bit in shock or something like that.

We've been around for a long time and we certainly will be around for a long time. I'm going to need your total undivided attention for what I'm going to tell you 'cause it's good news.

CMDR. (RA) NORMAN
STARKEY (cont'd):

So why don't you all just stand up.

Okay, turn around and say hello to the person behind you and shake their hand.

AUDIENCE:

(Laughter, talking.)

CMDR. (RA) NORMAN
STARKEY:

(Laughs.) Okay, find somebody next to you and shake their hand and say hello.

AUDIENCE:

(Hello, etc.)

CMDR. (RA) NORMAN
STARKEY:

Okay, and another one.

AUDIENCE:

(Hi, hello, etc.)

CMDR. (RA) NORMAN
STARKEY:

Okay, good. Touch a chair. Good, touch the floor. (Sound of touching the floor.) Good, sit down. Ah, got a little bit more attention there.

AUDIENCE:

(Laughter.)

CMDR. (RA) NORMAN
STARKEY:

Okay, I have good news for you.

Put up your hands of those who were at the original Mission Holder's Convention where I also said something. Down in Clearwater. OK.

At that time something was said about the legal scene. And I was soliciting some help to handle some of the damage claims suits which were brought against the Church and which named L. Ron Hubbard, as the Founder, named Church of Scientology of California and several others. At that time there were about 20 suits. But now that war is pretty much over, and the tide has definitely turned in our favor. I'm going to tell you a couple little specifics about it so you get reality on how it is.

We now know the source of this. We now know exactly how it started. Investigators, competent attorneys and some honest people running the legal scene who knew what they were doing and were following LRH's technology have brought this about. We now know that originally a decision was made by some people to file suit in the name of Julie Christofferson in Portland, Oregon. It was a test case to see if they could get Scientology kicked out of the area. That case was at first horribly lost in the State Court through mismanagement, poor counsel, bad briefing and incompetence in the GO Legal at that time. That resulted in a 2.3 million dollar judgement awarded against the Church of Scientology.

That made big headlines. Attorney Michal Flynn came onto the scene and felt there was money to be made out of the Church of Scientology. But he also had a public. He had a small "public" of ex-Scientologists who had been given out-tech. Or not given the real tech at all.

Now, when you tell somebody about Scientology and you tell them about the road to truth, you tell them about getting out of the trap and

CMDR. (RA) NORMAN
STARKEY (cont'd):

you tell them about the basics of the technology itself they understand it and they know that. That's why you're here and that's why people come in and start on Scientology. If you tell them that and you explain to them how the tech works and you explain to them what can be achieved and what can be gained in Scientology and then don't do that you ARC break them. Correct?

AUDIENCE:

(Agreement.)

CMDR. (RA) NORMAN
STARKEY:

Proportional to the amount of ARC or intention that existed in the first place. There were a lot of them out there and there are still some people out there due to out-tech or non-delivery of the technology which they were promised. They were told they could get this, they came in, they couldn't find it, they went out, they were upset. They wanted to get their money back. They were potential clients for Michael Flynn.

Now we know Michael Flynn's plans because we do happen to have through having been exposed in the court, copies of an original handwritten plan on the destruction of Scientology.

Basically this plan shows how Phase I was to file a Class Action suit. A Class Action suit is where one or more individuals represent a body of people or a class, right? Like for instance, somebody who owns a Pinto might file a suit as a Class Action suit representing all those who own Pintos if the gas tank is in an incorrect place in which case you don't have to have every single Pinto owner go into court. One or more people do that and then the judgement is rendered and then all those are in that same situation to reap the same benefits. Clear?

His plan was to file a Class Action suit -- which he did, in Boston -- using Lavinda Van Schaick and one or two others and they would represent the Class of these purported hundreds of thousands of ex-Scientologist who were "duped" into coming into a religion under false pretenses and who were in some way or other harassed, money ripped off or whatever. These are the various allegations which he threw into the complaint.

His plan was to do that and ask for a 200 million dollar damage claim, which he did. His plan was then to seek an attachment on the reserves of Scientology. An attachment is something you can do where you feel that there's a valid cause of action and you're going to seek damages in a judgement, then you can ask for an attachment or a court order to hold that money pending the judgement itself.

So his idea was to tie up 200 million dollars, then to build up the Class Action suit through the media which he admits to having total control of (including a fellow named Methvin from the Reader's Digest who was totally in on this). Then to put out a series of articles announcing the fact that this law suit was there and

CMDR. (RA) NORMAN
STARKEY (cont'd):

solicit the writing of these articles called "The Sickness Spreads", etc., which is all a bunch of total lies. Then the plan was to solicit various clients from the article responses, telling them to write in to Michael Flynn giving their name and address. Then to take those clients and instead of joining them in the Class Action suit, filing a diversity of lawsuits all around the country asking several million dollars damages in each suit so filed.

Not only that but part of the Class Action suit requested governmental assistance to take the Church into receivership and to replace its Board of Directors! Right there in the original complaint. Asking for a new Board of Directors to be appointed and be taken into receivership! We do know that Attorney Michael Flynn is very good buddies with Dr. John Clark, the psychiatrist who gave testimony in the Christofferson case in Portland, plus Margaret Singer, another psychiatrist.

Flynn's plan was then to create a diversity of law suits, filed around the country, asking for several million dollars. And then force the Church into a settlement posture because he would be forcing the Church to litigate these cases but they would have no financial reserves 'cause the 200 million would be tied up. And once you force someone into one settlement, of course, it just brings about more. And all the while stirring up further clients by offering them that if they came in and gave testimony, they could get themselves a couple of million bucks. That was the scheme.

A corporation was formed by Flynn called FAMCO (Flynn Associate Management Corporation) where shares were sold in order to raise funds on his behalf and to solicit attorneys around the country in this massive money making venture. And the shares would then pay dividends on the damages awarded from the various lawsuits. That's about as much of the plan that you need to know about. But it was a plan to wipe out and destroy Scientology. It was a plan to use the forum of the legal area to spread disaffection, bad news and seek bad press. So that was one angle of attack. And it was also a forum in which to try and tie up our finances and then drive us to bankruptcy. One of the claims in one of these cases was RICO (Racketeering Influenced and Corrupt Organization) which is what Attorney Flynn hoped very much to get, which would have given him not only triple damages but would've then forced us out of the protection of the First Amendment Clause (which entitles a religious entity to practice on its own and is not subject to outside intervention or any discussions within the courts as to what our beliefs, precepts, etc., are).

So, now we had this Class Action suit which consisted of counts from fraud to intentional

CMDR. (RA) NORMAN
STARKEY (cont'd):

infliction of emotional distress, through violation of the Fair Labour Standards Act (by not paying Lavinda Van Schaick minimum wage standards for working in the Church), for promising her that she would be on the ship with Ron and then not doing so (as if it was some sort of an obligation to do within the Church), through Racketeering, Influenced and Corrupt Organization.

A motion to dismiss was filed in that case based on the legal issues, not even the factual points, on the legal issues, which reduced that class action down to: no longer a class, our Founder no longer involved in that suit, Church of Scientology of California, no longer involved in that suit and from 14 counts down to 5. At which point Attorney Flynn decided, wow, I'm in trouble I better get this case to trial now. So he dropped 3 of them voluntarily and left only 2, and said he wanted to go to trial immediately on those 2. Of course we're not interested in losing that case. That case could've been settled out long time ago. We could've said; Okay, drop the whole case, but we're not interested in doing that.

We have this case because it is also a vehicle for a malicious prosecution and abuse of the process lawsuit against the plaintiffs once we win it. Also because we're right now filing what is called a motion for summary judgement which will receive from that judge a judicial statement that Scientology is a bona fide religion entitled to the protection of the free enterprise Clause. But Mr. Flynn is now fighting like crazy to try and drop that other count and has made special application to the judge to please allow him to drop this count because he will NOT, does NOT want Scientology declared as a religious entity.

But, we did have in this Christofferson case the beginnings of this whole thing where this 2.3 million dollar judgement was rendered. It was taken up by us to the Appeal Court, and the 2.3 million judgement and the original loss in this suit was reversed, turning it into a resounding win for us.

I'll quote you just a couple of things which are quite relevant from this Appeal Court decision.

"We have determined that the record in this case establishes as a matter of law that Scientology is a religion, the jury should have been so informed." That is now printed in a law book, distributed out from the state of Oregon. Court of Appeals is law, right?

(Applause.)

AUDIENCE:

CMDR. (RA) NORMAN
STARKEY:

Okay, let's just breeze through a couple more. We will look at some other cases and wins we have had recently. First let's look at just how many wins we have had in this Van Schaick case. I'll give you some statements from this thing, right?

CDR. (RA) NORMAN
STARKEY (cont'd):

Now just from the state of Massachusetts: "Van Schaick's reliance on the conspiracy theory is based on nothing but speculation and conjecture on the essential issues of connecting each of the corporate defendants with acts or transactions within the forum state. She simply hopes 'Somehow and somewhere to find enough facts to create grounds for jurisdiction'." On this RICO claim this judge has stated: "The RICO claims must be dismissed. The Church of Scientology cannot at once be both the associated person and the enterprise. It is only a person or one associated with an enterprise. Not the enterprise itself. One can violate the provisions of the section." Couple more here: "Count 10 alleges that defendants have engaged in a systematic course of conduct". (That's Flynn's basic quote -- it's full of generalities and so forth - "engaged upon a systematic course of conduct".) The judge says: "Count 10 alleges the defendants have engaged a systematic course of conduct to disclose information received through auditing and that such a theme has caused Plaintiff severe emotional distress. Yet Count 10 alleges no specific disclosures and the only one the Plaintiff specifies is a letter to Plaintiff's attorney."

That's all that was actually found. With respect to Count 11, "Plaintiff alleges only that the Church exalted her to save her family and marital ties and to depend solely on the Church for emotional support. Neither of these alleged courses of conduct constitutes the kind of extreme or outrageous action which will support a claim for intentional infliction of emotional distress. They are simply similar to the demands for single minded loyalty and purpose that have characterized numerous religious, political, military and social movements over the ages."

See what has happened here.

(Now some of you might have had withholds and you might have been sitting in an out-ethics situation - which is why we're inviting you -- and we will later on -- clean up your act. Because if you're sitting in an out-ethics situation yourself there's no way that you can be at cause. Because you're at effect of your own actions. And when you're at effect of something and you have to come up against an opposition, you're starting from effect, you're going to get wiped out. You might be able to start getting it going but in the end you're going to get wiped out.)

So what we did, we just cleaned out all the out-ethicsness and put some competent people there and we started pulling the strings.

Before, we were not getting the judicial decisions that we sought. And now we're getting them because we know who we are. And we know the position that we represent. And if you're coming from an honest viewpoint you can demand that. True?

AUDIENCE:

(True, yeah.)

CMDR. (RA) NORMAN
STARKEY:

Couple, just one or two more. 'Okay. I could ramble on forever but there's a big wad of them there in all these different cases.

What I want to just mention to you here now, was, some of the allegations. Now this thing came about, and you might have heard some of these allegations in some of these complaints. right? And that Tonja Burden was saying that she was imprisoned at Flag and there was all these nasty things going on.

Bill Franks was neh, neh, neh, neh, "CMO locked me up" and all that pack of lies.

Okay. You get this complaint and it looks, ahh it looks terrible, it looks staggering, it's very badly (but cleverly) written. It is done in a way to try and convince some people to see that there was something valid here. And of course they would then use this to get into the forum of the press to get press articles and so forth.

Okay, so how do we handle this, we just get the person in who was supposed to have said this, sit them down, put them under oath and then ask them the questions. While they're under oath. Or perhaps get an investigator through an attorney to find out some of these facts and see if they are true or if she's saying something to somebody else and saying -- I've really got these suckers -- you know!

So here we go, here's a couple of examples:

Tonja Burden, she claims that she was imprisoned and prevented from leaving the Church and had to sneak out without anyone seeing her. So we called in her uncle and got him into a deposition (which is simply an attorney, and the person we depose, and it's under oath and everything that they say is taken down in writing).

In the deposition of Tonja's uncle, he tells the story of Tonja leaving very differently by saying that he simply went to the Fort Harrison to pick her up. He went into the front of the Fort Harrison, met her in the lobby and they walked out the front door together! (Some chuckles from audience.)

That's contrary facts, right? Must be a situation here. (Laughter from audience.)

Jefferson, the 4 cases in Los Angeles: Peterson, Jefferson, Garrity, Lockwood. You probably know them, they were in the missions, they've been in the orgs, they've been around.

One of them claims he couldn't play a better game of golf and so therefore it's a fraud because he was promised he could play a better game of golf. But I tell you, that you're

CMDR. (RA) NORMAN
STARKEY (cont'd):

going to look in his pc folder and you're going to look at his personnel file and you find out that somewhere down the track this guy was making gains and he's got some glowing success stories and his graph was going up, so he was getting benefits from it.

Somewhere down the lines, he went out ethics or maybe he shouldn't have been allowed on lines, so some out-tech occurred at which point the guy started to go off the rails and became "anti-us"!

In the complaint Thomas Jefferson claims that data from his auditing folder was disseminated and used against him. Big claim, right? We go and get him into a deposition. In the deposition taken on 14 and 15 October 82 he said he did not feel anything from his auditing was disseminated or used against him. Yet it's there in his complaint! In the complaint Jefferson claims he was under severe emotional distress because of what it did to him, however in his deposition he said that he never had any periods of severe depression in his life and has not had any severe distress.

In his complaint Jefferson claims Scientology intentionally lied to him to get him to pay money to the Church for courses and auditing. In his deposition (taken under oath) he says throughout that the Church persons he dealt with regarding signing up for courses or auditing were sincere in their beliefs that by having him take the courses or auditing he would benefit personally and would increase his abilities. In the complaint Jefferson claims the Church engaged in "terror tactics" against him. In the deposition he flatly denies that there were any terror tactics ever used against him!

Right. And it goes on for pages, and page after page after page that I'm not going to bother you with, but in other words, in brief, it's just a pack of lies. But that's what it is, it's just based on lies which were generated by some people outside but then there was a public in which to forward it.

So those who have come to us now and been part of our side, great. We're trucking along. There have been a few who thought that they could go and join what they thought was the winning team - Michael Flynn. Brown McKee was one of them. He was down at the last Mission Holder's Convention, drunk, been drinking. Standing up and saying, "I'M BLOODY MAD ABOUT ALL THIS STUFF" you know and all these threatening accusations. For sure this man has an out-ethics situation here. What do you know there was. He runs up and says, Oh, I'm going to get rid of my mission and I'm turning into an org and so forth. Where is he now? He was working for Flynn! He will never, ever, ever and I promise you, for any life time, ever again get on any auditing or ever have a chance to get out of his trap. And

CMDR. (RA) NORMAN
STARKEY (cont'd):

those who are on OT 3 knows what that means! That means lying and dying and dying and dying again. Forever, for eternity. We don't owe anybody Scientology Technology. But if he wants to try to stop the progress of the group, I personally, as well as all those here and others have the responsibility (which is a tremendous responsibility) to ensure that Scientology is here as a bridge for the entire humanity and this planet alone let along this universe as a way out, and we will take action in the defence of our Religion.

If anybody's going to try to stop that, and if I didn't stop them from trying to stop it, it would be an overt that I would be committing. And the rest of us.

Which is why you'll find we are very firm on these matters. When I walked in here and gave an order to be done it was not complied with, that's the way things will get done. Tough. But that's the way it has to be done. Not because I want to be smart or big or anything like that, it's because the awareness of the responsibility which each and everyone of you have to share as well.

If we are forced into taking action with legal, we will. Our religion means a lot to us and we will do all we can to ensure it is protected.

Anyway, that's the good news. We are winning and this is the winning side. And thank you for those who have helped.

AUDIENCE:

(Applause.)

CMDR. DAVID
MISCAVIGE:

Thank you Mr. Starkey. The next person that's going to be speaking is Commander Ray Mithoff. He is the new Senior C/S International and he's going to be speaking to you more on tech matters.

Mr. Mithoff.

AUDIENCE:

(Applause.)

CMDR. RAY MITHOFF,
SENIOR C/S INTER-
NATIONAL:

Hi.

AUDIENCE:

Hi.

CMDR. RAY MITHOFF:

Tonight you've heard a bit about this recent epidemic of this squirrel tech, it was largely from what I've found out so far, going on in missions, a number of missions, and it even spread to a few org staff. It really disgusted me when I found out. It's not just that one person went crazy and invented something, because as you've all seen in Keeping Scientology Working Policy Letter, LKH says that occasionally you'll have somebody who'll go nuts and try to invent new tech to wipe out Scientology.

But I was particularly disgusted when I found out that other people and other staffs, mission

CMDR. RAY MITHOFF
(cont'd):

staffs in particular went along with this, thought it was great... somehow got that tied into an alter-is of an LRH Policy Letter on Simon Bolivar and somehow got this all tied in (and mind you, this is not accidental, at all), tied this into bribery so that one can say that, "I'm going to flow power to you and that way... that means sticking a bunch of money in somebody else's pocket you will then, of course, overlook any out-ethics you might be involved in."

That is not, and has nothing whatsoever to do with the Policy Letter or does it have anything to do with tech. There's been a long term situation... I've been on tech lines for over 11 years. I know myself, personally, there's been a long term situation of, where orgs are regarded as these places where you're supposed to do standard tech but out in the field beyond orgs well, you can kind of get away with other things. And, that attitude has got to change. It doesn't mean every mission is going to be made into an org or that every mission is supposed to act exactly like a Class IV org or Saint Hill or an AO but it does mean that when you do apply tech, even if it's an HQS course you're delivering or a HAS course, Success Through Communication, whatever it is you're delivering, it's got to be done standardly.

The Policy Letter, Keeping Scientology Working, it does apply to missions. There is no statement on it anywhere that this only applies to Class IV orgs. It doesn't state that anywhere. You can work in a mission, you can work as a Field Auditor or Field Group, a Gung-Ho group, a Dianetic Counselling Group, even if it's just simply carrying around a Self Analysis book and grabbing somebody and running them on some straightwire to a time they felt good and they feel better. Great. It can still be done standardly.

The attention here is as you've heard tonight on mentioning getting the scene going straight, the intention is to get it standard, not just in orgs (and believe me, it's getting standard in orgs too), but tonight I'm addressing mission staff; to get things standard in missions and get them operating on policy using HCOB tech and just not listening whatsoever to anybody who's coming along promising a better way through the use of squirrelling. Promising a different path, telling you it's Scientology when it really isn't and trying to get you to believe it and they if you don't believe it, putting money in your wallet to trying to make you think you now believe it.

There have been some instances uncovered recently (you all may or may not know that I'm also Chairman of a Comm Ev. that's going on), there've been some instances recently of people getting bribed and that's all part of this same "dinging" tech thing and I can assure you that I am not

CMDR. RAY MITHOFF
(cont'd):

going to take any bribes, so anybody here who had any kind of ideas of sending me a present, money, new clothes, new car -- nope, I don't want it.

Bribing somebody is solely and only an effort to get the person to take his attention off of your own withholds. That's all it is. If you're committing out-tech or, I mean, you can watch some gangster movie on TV where they bribe some guard at the border to look the other direction while they smuggle machine guns across or something like that. That's all that bribery is. There's nothing more to it.

Money changes hands for an exchange and that is... in Scientology we use that commodity of exchange, the person pays money and they get service. Not... the service rendered is Scientology and Dianetics technology, not looking the other way or being a nice guy and not turning in your buddy who is squirrelling and so on.

If you don't understand what I'm saying you can read the Tech Volumes which cover, very clearly, that the Tech is to be kept pure, it's there to be used to make man free and to get better, increase awareness, increase abilities, it's not there to be knocked around, alter-is'd and smeared and then covered up with bribery.

I wanted to mention, the thing of this "dinging". I've heard about some of these things and I've seen first hand reports of them, I've actually seen people who were messed around by this. Such things as students studying in a courseroom, you have all these students who have come to the mission, they've paid their money, they want to do a course, they're in the courseroom studying and on the Course Supervisor's desk there's this bell and this guy, everytime he... apparently everytime the Supervisor (who must have been a complete psychotic), everytime he dived into his own mental pictures and decided he was being suppressed or something would ring this bell, at which point some other idiots would come and drag some student out of the courseroom and take him into a closet and run some ridiculous bunch of commands on him and then tell him to go out and sell books or something like this.

Now you all just stop and think, if LRH walked into that courseroom and saw that, what do you think he would do?

I know a lot of you have been around many years and a lot of you have read an awful lot of stuff that Ron has written. Now what do you think he would do?

You know that in policy, LRH has written in Policy Letters that, you're wearing that hat - his hat for that post. Because he's held every post there has been in the past. He's

CMDR. RAY MITHOFF
(cont'd):

written all the policy on how to do these posts. So you're standing there in this courseroom and they're doing this and they're saying this is a Scientology courseroom. No-o-o it isn't. There is no resemblance between that and anything in any Scientology book, tape, PAB anywhere there's no resemblance to Scientology.

The future can be either very bright or very bad. I know for me it's going to be very bright and for someone who's out there squirreling and trying to get other people's attention off of Scientology and onto something, just to fatten their own pocket or whatever that person's future is black.

You hear Mr. Starkey mention a bit of how black it is. It is really black. It is so black I can't even describe it right now. I can't even find the words to describe how black that person's future is. In fact it is almost as black as the future of an FBI Agent. I mean it is really black. The depth of that blackness and the length of time that that person will be in oblivion is just immeasurable.

I'm not going to... it's not any act of mine that's going to make his life that miserable. But there is such a thing as infinity and you're in it whether you like it or not, as is pointed out in a recent LRH ED and good or bad you'll be in this future. And those who have tried to tear down Scientology Oh, boy!

I think the only thing lower would probably be an FBI Agent. But that person would be kind of like a... kind of like this (knocks on wood desktop). So he's a little better off 'cause he doesn't even know that he is a piece of wood.

Like I said the future is bright though. You've seen recently, I'm sure you all who get new issues, you've seen two new LRH HOOBs, C/S Series 115 and 116. Have you seen these?

AUDIENCE:

A couple of people say: "115".

CMDR. RAY MITHOFF:

115. Well you guys got to get the new issues that come out. And these are regards cleaning up some things that have been going on which are out-tech. There is a new rundown which is going to be released very shortly. I can't tell you anymore about it.

AUDIENCE:

(Chuckles.)

CMDR. RAY MITHOFF:

It'll be very, very exciting I do not know whether missions will be delivering it or not at this time. I really don't know, it's going to be very, very popular with staff and public. The research on it is incredible and very, very vast and a lot of work is going in on it.

The upper of levels, Solo N97s, New OT 8, New OT 9, 10, 11 -- these levels are amazing.

CMDR. RAY NITHOFF
(cont'd):

They are amazing beyond your belief. These things are all there and it's a very bright future.

Those of you who see to it, for some reason or another to fall by the wayside and get caught up in squirrelling get into a thing of trying to tip-off pcs from orgs or downgrade tech or join up with squirrels. Jack Horner, that's another famous squirrel, I was thinking of. Join up with some squirrel like Jack Horner, try to audit some piece of tech that you've invented and call it Scientology or take a piece of Scientology that is Scientology tech and go out and try to sell it to somebody and call it something else, call it, you know, Whiz-Bangs or something. You do something like that I can assure you you will have no more certs, you won't even have the corner of your HAS Course cert. You won't even have the thumbtack to pin it on the wall. You won't have any certificates, you won't get any auditing and I can see to it that you won't. And you particularly won't get anymore OT levels, nothing, if you persist. Like I said, if someone here persists in squirrelling or getting others to squirrel or just standing there like this while your buddy is wrecking Scientology, just standing there (whistling) like that, which I consider just as gross. And if you all read the new 1982 Policy Letter called Knowledge Reports, you'll see what I mean. If you just stand right there and say, well, okay, let this guy wreck Scientology. From my post I can very much assure that you will never, ever get anywhere near any Scientology book, meter, anything and I can request of persons in RTC to see to it that other measures are taken. But I can assure you that you will not have anymore certs whatsoever and anyone in this room right now who goes out and tries to do anything even vaguely resembling this "dinging" thing of ringing the bell in the courseroom or locking students in closets or ah, telling every single public person that walks in the door that they're PTS because they have money or something like this, anybody who gets into this thing and I find out about it (and I will because of my comm lines aravery, very far reaching right now) I can tell you you won't have anything left. Nothing.

The good news though... There is some good news here. And that is, if you all really get with it, standard tech, apply your HCOBs the way they're written, get on with the show, get lots of pcs moved through the courses that you're delivering, flow them over to orgs, support your orgs, support standard tech, apply what's in the tech volumes, study your courses, when you have a courseroom you run it with a supervisor and chairs and tables you know. Picture of LRH on the wall, not a picture of a squirrel or something, picture of LRH, you have clay and checksheets and you run a regular course, teach a regular courseroom, you run it standardly -- if you do these

CMDR. RAY MITHOFF
(cont'd):

things and they're very, very easy to do then I'll back you up totally, the entirety of this thing called CSI here, Church of Scientology International will back you up completely and so will RTC. You will have the full support of Flag, Management and technical execs all over the place who are working on getting programs done to upgrade application and get more auditors made, you'll benefit from all of these things.

I will personally do whatever I can to help you, get you... make sure you get more bulletins. Some of you haven't gotten these new bulletins I was mentioning. Make sure that all these things occur and that you have a really good time of it, that you make lots and lots of course completions and that you do lots and lots of auditing and training and make good money. I'll be totally willing to back you up on all these things.

I do want you to know though that there is no fooling around now. There's no more bribery, let's just leave that to other planets, other civilizations, other countries, some other countries are still in this as well. No more of this kind of corruption and bribery no more squirrelling, nothing like this. Let's just get standard Scientology being delivered and I'll back you up all the way. And I can assure you that I won't be the only one that will be pleased that you're delivering standard tech.

Do I have everyone's agreement on this?

YES.

AUDIENCE:

CMDR. RAY MITHOFF:

Good, thank you.

AUDIENCE:

(Applause.)

CMDR. DAVID
MISCAVIGE:

Okay, the next person that's going to be speaking is Captain Marc Yager. He's the Commanding Officer of CMO International and he's going to be briefing you on organizations and missions and flowlines for the entire bridge of Scientology. Mr. Yager.

AUDIENCE:

(Applause.)

CAPT. MARC YAGER:

Hello. Earlier, Warrant Officer Spurlock showed you a corporate chart and I want to show you how the ecclesiastical lines of that chart work. Because in Scientology we have a flowline that runs up in terms of the bottom of the Bridge to the top of the Bridge.

(Pulls out chalk board to show audience.)
(See Chart 3.)

Here at the top is the PBO, under that you have Advanced Orgs, Saint Hills, Class IV Orgs and missions. You also have under that Field Auditors and under all this is the public.

CAPT. MARC YAGER
(cont'd):

And what we have is a flowline where Field Auditors, missions and Class IV orgs as well, but starting at the bottom, get Scientology public in, they flow them up to the Class IV org where they will be trained as auditors or continue on the grade chart as pcs.

From the Class IV Org, those public would go up to Saint Hills and get trained further so you have more expert technical personnel. They will also get more services, advanced services at the AO and eventually their upper levels, Solo NOTs and so forth at the FSO.

So this works as a bridge and the lines go up through all these organizations like this... Now, one of the key breakdowns that can occur is where one part of the flow line stops; if a Field Auditor holds onto its public, you've wiped out one line. If a mission holds onto its public, it's wiped out a line. If a Class IV Org does, it wipes out the line. The only organization that will have its public forever and ever and ever is going to be the FSO as they will have the highest services.

The object is: we have 4 billion people on this planet, more than enough for everyone to have plenty of public. There's no shortage. We have to push all these people up the bridge. A problem has been Missions hanging onto public and delivering them everything they could instead of moving them up the bridge.

We're not going to get the planet cleared if we just deliver them arbitrary services. We deliver the Grade Chart and, with proper Bridge flowlines, we will actually get all these public, all 4 billion of them up the line.

Now what goes with this, is, we have corporate command lines in management already shown to you which is the CSI and below that there are FOLOs and below CSI is also SMI International.

One object of these various organizations is to see that the flow UP the bridge is always maintained. And by keeping the flow going up, we will all make progress. So the flow IS from Missions to Orgs to SHs and AOs to Flag.

Now, at the previous Mission Holders Convention held at the end of '81, I know there were complaints about "bad management". Franks was one of the major concerned parties. Later we found new management, such as Barnes and Axcel complaining of management or advices on Missions being based on false data. Well, we investigated each of these persons and instances and the startling truth of the matter is that there were two common denominators. The complaints about Management operating on false data about the Missions turned out to be untrue. Factually - the only data management did have about Missions were from those themselves who were nattering!! And secondly that the SAME persons nattering about Management were actually THE persons in management doing the actions they

CAPT. MARC YAGER
(cont'd):

were nattering about! Quite a twist, but all very documented and true.

A thorough investigation is currently ongoing by way of a comm-ev, and we are finding in every instance that natter about management being "bad" always comes back to the persons nattering being THE persons taking the actions which they have been nattering about.

Franks himself was found to be operating solely on the orders of Alan Walters, who is about as squirrel as they come and who actually has developed his own technology. Quite squirrel. But - it certainly does explain the natter about those who really were trying to get the job done. Yes, they were quite a threat as they would cut off the bribes people like Barnes and Franks were getting.

So the point is that you should know that these management structures at the top are clean, and their purpose is to see that this bridge flows. Sometimes that can get lost if you feel your communication is unanswered. Well, everybody in this group has to participate and be part of the group and take responsibility for it. If you don't take responsibility for it you're not being a true group member, and that's the way it is.

SMI is being built back up with strong individuals that will back up missions and by that I mean see to it that you can apply standard tech and you have the LRH materials to hand and so on. Because that's what's going to make us go free. That's what's going to get the bridge to roll and the rest of CSI is there, the IMO is there, WDC, the Executive Strata to see that the organization rolls. And as the machine rolls it'll expand, it'll get bigger, more and more people will get into Scientology and we'll have the planet and that's the object. And that is where everyone should be putting their attention. That is the intention, right?

That's all I have. Thank you.

(Applause.)

Thank you.

It is quite interesting how we found out that those nattering about management were the management they themselves were nattering about. And that in all instances, we found that the actions which they nattered about were always something they themselves originated. They were only nattering about themselves.

Now many of you were there at the earlier Mission Holders convention at the end of last year. While Franks was nattering about how bad everything was and how he wanted to start running things his own way as the STANDARD way wasn't right, the audience was cheering him on. And yet the ideas he was forwarding were

AUDIENCE:

CMDR. DAVID
MISCAVIGE:

CMDR. DAVID
MISCAVIGE (cont'd):

those of Alan Walter's. Alan Walters claims all sorts of stats but when these were investigated, they of course were found to be false and in actuality his only stats are crashed orgs and missions wherever he goes.

And even after all of this, we find that again, someone, like Wimbush, is inventing their own tech. And Howard Rower has Bill Franks working in his mission.

Now look - the tech is there. And the ONLY workable Tech is STANDARD TECH.

This squirrel tech and off-sourceness ends right here. Kingsley is declared and actions are going forward to get him criminally prosecuted for trademark violations. Howard Rower will be declared and also investigated for possible prosecution. These bribe days are over. These squirrel days are over. The rip-off days are over. There is a new corporate structure and standard flowlines exist for the entire bridge. And that is actually the good news. Because we are making it and we are winning. And the organization is formidable. And the only way anything will be getting done these days is the standard way, and that is how we are going to clear this planet.

Right on! (Yeah! etc.)

Next person I'm going to introduce is the new Executive Director International. His name is Guillaume Lesevre and he used to be the CO of POLO EU. As CO POLO EU he had the biggest orgs in the world. He has real stats. And although he's not your direct senior, he is senior, both corporately and ecclesiastically to missions. And he's going to be briefing you on what's needed from you in regards to International Strategic Planning and where the missions fit into that. Captain Lesevre.

(Applause.)

Hi...

Hi.

I've been building orgs and running orgs for the last 6 years. When I started in Europe there were 10 Class IV orgs, there are now 34 Class IV Orgs.

So honestly, I know what I'm talking about. Now all the time I've been doing that there's one thing that struck me very strongly. One major situation that I've been running into... the biggest block on the bridge and that is the flow from the mission to the nearest Class IV Org.

Now this is a situation, this is a situation that I've noticed in Europe, it's even worse in the United States. Last week out of 83 or

AUDIENCE:

CMDR. DAVID
MISCAVIGE:

AUDIENCE:

CAPT. GUILLAUME
LESEVRE:

AUDIENCE:

CAPT. GUILLAUME
LESEVRE:

CAPT. GUILLAUME
LESEVRE (cont'd):

84 missions, there were 15 people sent to an org. In one week! Now this is a situation! I'm not asking you what's needed and wanted from me, right now. I'm going to tell you what's needed and wanted from you. Because I can tell you honestly I'm not talking in generalities, I've got experience, I was this afternoon in San Francisco Org, you know, and in 45 minutes I got 60 persons into that org myself.

A lot of things have been happening that have been gone over by previous people have been speaking such as squirrelling. We have instances of missions selling Academy packages and things like that..

I know of that in Europe, I know that if that has been happening in Europe it has been happening in the United States. But the main situation is that they don't send the public to the nearest Class IV Org.

Sometimes they'll send them to FSO, but they won't send them to the nearest Class IV org because there "the tech is not good" or "our public is so upstat and the org is so dirty that we can't send them because afterwards we have to rehandle them".

Anyone of you every heard that? Be honest. Tell the truth. I've heard that, I've heard for that for years. Now it's going to be handled. It's going to be finished. The flow up the bridge is from the missions to the nearest Class IV org and I mean the nearest one.

Now if it ever comes to your mind or if anybody tells you you shouldn't do that "because it's a Class IV org, it's not good. It should be handled by higher management first", well you should write up your O/Ws as this is a justification. You wear your own hat, you take responsibility for your hat, you send people to the nearest Class IV Org. What do you get in exchange? You want to know what you get in exchange, I was told maybe you were wondering what you would then get personally. You get a Clear planet. That's what you would get.

You have a hat to wear, I have a hat to wear. As a Commanding Officer for many years, one of the main things I've been dealing with is people not wearing their hat. You Mission Holders, you know what I'm talking about. Don't you?

Now I'm asking you to wear your hat and send the people to the nearest Class IV Org. This way the bridge can flow. The other thing I'm asking you is to get out, reach out to the new public. That's your hat. That's why you're there. To get the new public into the mission, give them Book One auditing, sell them DMSMH not Ruth Minehull's books, not Peter Gillham's books as that's off-Source! That's not the way.

CAPT. GUILLAUME
LESEVRE (cont'd):

You sell LRH books ONLY! Those other people are just trying to make money out of the L. Ron Hubbard's technology.

You get those people in, you give them Book One auditing, introduce them to the basics of Dianetics and Scientology -- that's your hat. That's why you're there.

That's all I care about. That's all I am interested in. And I repeat and stress the nearest Class IV org. That's your Class IV org. If you feel "it is too dirty, not clean enough", send more public in there. Take responsibility for it.

It has always struck me, from the first day I have been in Scientology that people could criticize anything about Scientology or an organization. Why don't they come in and help? That's always amazed me. The same applies on the Third Dynamic. If we want to reach our purpose... you see, we are all an organization, there are different corporations but this whole thing is one movement. We are a Third Dynamic handling the Fourth Dynamic.

Now an organization is a group of people working together with a common purpose. But it's a group of people working in a coordinated way and organized way. Everyone wearing his hat. Not a mob! Somebody doing OP 4D over there, somebody selling Ruth Mishull book over there. Everybody doing what he thinks should really be done. Know-besting around.

I'm talking to you like if I was talking to my own staff members as I've done for years.

Now, I'm going to give some quotas of people you're going to have to send to the nearest Class IV org.

Now, these quotas are very low. We're going to take that on a gradient. However if we meet those this week we're going to be at least 20 times, it's going to be 20 times more than what was produced last week.

I'm just going to go down that list; give you the quotas of pcs and students to send to the nearest Class IV org. Those quotas by the way are going to be published, sent to all the missions, sent to all the orgs. I will make sure those orgs are on the phone to you and asking you where are all those people you're going to send this week?

You give them the lower end of the bridge, auditing and then you send them on to the nearest Class IV org. Now if you send them to get their DCSI, they stay in that org. They don't come back into the mission they stay in the org and they carry on up that road. And then you don't cry because you don't have your public anymore. A mission or an org is not a club. It's not a selected club, selective club --

CAPT. GUILLAUME
LESEVRE (cont'd):

you go out in the street and get some more people in.

We've got to clear the planet. We're not there to make a club. I know exactly what I'm talking about. I'm sure you do also. This is going to change now. It is a major situation.

Now, being a major situation it's stopping the progress of Scientology clearing the planet. Now, as you've heard, now is the time where we're going to count who is with us and who is against us.

The missions are going to wear their hat. They'll be treated like any staff member, like LRH treats people that are wearing their hat. He backs them up all the way. Missions that don't, they'll be looked into. They'll be handled. There will be a reason under it as why they don't do that. Some money things, whatever. Some personal interest. We have no time for that. I'm sorry if I'm not making a PR talk but personally, honestly I think this situation has to come to an end. It's been going too slow and we want to clear that planet while we still have the time. What do you guys think?

AUDIENCE:

(Yeah!)

CAPT. GUILLAUME
LESEVRE:

Now, you see in orgs and per policy, per LRH policy, the way we see if people are wearing their hats; the production is measured by statistics. This is covered in policy. Now, the statistics of the missions I will be looking at to see if you wear your hat is: every week, the number of public and the number of pcs and students, every one of the missions are sending to their nearest Class IV org and the number of new people they start on their first service in the mission.

I'm just going to read on. Boulder Mission, and those quotas, by the way, are to be met this week and they also valid for the week after. Afterwards we increase them.

Boulder Mission - 4 pcs and students this week.
Chico Mission - 8
Colorado Springs - 4
Denver - 10
South Denver - 4
Encanto - 2
Fairbanks - 3
Fresno - 4
Honolulu - 4
Houston - 4
Omaha - 4
Richardson - 6
San Antonio - 4
Salt Lake City - 4
Sausalito - 4
Stockton - 4
Lynwood - 3
Marin - 4
Mid Peninsula - 4
Monterey - 3

CAPT. GUILLAUME
LESEVRE (cont'd):

Mountain View - 8
Palo Alto - 20
Riverside - 6
Sacramento - 4
Santa Cruz - 3
Seattle - 4
South Bay - 3
South San Jose - 3
Southwest - 16
Stevens Creek - 16
University Way - 8
Westwood - 4
Tucson - 4
Reno/Tahoe/Golden Gate - 4
Vista - 4
Bellevue - 6
Phoenix - 4
Adams Avenue - 4
Anaheim/Orange County - 8
Berkeley - 8
Buena Ventura - 4
Canoga Park - 5
East Bay - 6
Fremont - 3
Long Beach - 4
Los Gatos - 4
COSMOD Davis - 12
COSMOD Portland - 12
COSMOD Sacramento - 12
COSMOD San Francisco - 12
COSMOD Sheridan - 6

That's it on West US missions. If we get that done this week that's 302 public to orgs, to your nearest orgs against, well, I still have the East US missions to go, here are the quotas for East US missions:

Champaign - 6
Chicago - 4
CC Detroit - 6
Flint - 4
Highland Park - 8
Milwaukee - 3
Peoria - 4
Arlington - 10
Cambridge - 4
Cleveland - 4
Collingswood - 4
Elmira - 6
Fifth Ave - 6
CC NY - 20
New York - 10
Washington, DC - 8
Atlanta - 6
CC Clearwater - 6
Coral Gables - 6
Ft Lauderdale - 10
Puerto Rico - 11

That would make 146 from the East US missions this week to the nearest Class IV orgs and 302 students and pos from the West US missions.

I'll be looking at those stats, I'll know if you got what I mean and that's all I have to say for right now.

CAPT. GUILLAUME
LESEVRE (cont'd):

If you get this quota met, you're going to get backup. You're going to get all the backup in the world. You don't, you won't get backup and a lot of other things as well.

Thank you very much.

(Applause.)

AUDIENCE:

CMDR. DAVID
MISCAVIGE:

One thing the Executive Director International went over that's needed from the missions is Book One auditing, as a major action from missions: Getting new public in and getting them on Book One. Aside from the quota or whatever that's what's needed. Book One auditing. That's the bottom of the bridge, lots of resources One auditing. Doesn't take a lot of resources to deliver it, you all know that. So, Book I is needed from missions and in a big way.

Next person that's going to be speaking is Commander Wendell Reynolds. He is the International Finance Dictator. And he's also going to be talking about the promotion for this Book One Campaign and the upcoming Book One promotion.

Mr. Reynolds.

(Applause.)

AUDIENCE:

CMDR. WENDELL
REYNOLDS, INTER-
NATIONALAL FINANCE
DICTATOR:

All right now, collectively you guys are in some weird lower condition. By association if no other reason you have allowed the missions to go squirrel and I mean squirrel! Now, I don't know if you're aware of this but the Finance Network has recently been beefed up and we have an FBO and Deputy FBO on post in just about every org on the planet. The Deputy FBO's job is to drive public in on the orgs and the FBO's job is to get those public serviced. Now right now you guys are CI on my lines, maybe one exception in this room, but I doubt it, because you guys are sitting on public, you're ripping off the orgs, you're doing all manner of crazy things.

Now, we are going in on the orgs and we're finding this stuff. The \$250,000 that Stevens Creek has regged from people who had already gone Clear over the last few months -- somebody's already paid for it and there are some more dues to be paid on that one. I'm not going to have this stuff.

Now some of these guys you see standing around here are International Finance Police and their job is to go out and find this stuff and if you guys are guilty of it, you've just had it! So, are we talking the same language here, now?

Anybody have any doubts about this one?
(Pause.) Okay.

The old routine here was you got Scientology justice procedures applied to you when you did something wrong. Well you guys are a separate

CMDR. WENDELL
REYNOLDS, INTER-
NATIONAL FINANCE
DICTATOR (cont'd):

corporation from the Church and when you rip-off or steal from the org, or bribe people it's a corporate crime and you can be real sure that you're going to all end up in the slammer.

Now, I figure that you guys owe these orgs, I don't know how many millions of dollars, how many hundreds of thousands of pcs from the rip-offs, collectively speaking. And I say collectively because you guys by association are taking on the condition that you failed to assign. And if you read the policy How To Assign Conditions you will see that the condition that you fail to assign you will take on. And there are people in this audience, right now, who are wholesale ripping off orgs. Anyone want to volunteer that they're doing it? Nobody here will volunteer? COSMOD San Francisco here? Are you COSMOD San Francisco? Is COSMOD San Francisco here? Is that you? Do you agree? I'm going to put you on the meter later on if you say no.

SOMEONE IN
AUDIENCE:

Me?

CMDR. WENDELL
REYNOLDS, INTER-
NATIONAL FINANCE
DICTATOR (cont'd):

No him. Okay.

I want some dues paid on this and I don't want these public coming into these orgs on these quotas to be the guys you're giving back having ripped them off. These are new people. Anybody ripping off comes back just as they went off the lines. No ifs, ands or buts. No walking into the org, take the pc folders and take them up to the missions, none of that stuff. You guys are a flow up, not a flow down and not a holding action.

Now, this convention is costing the Church money. You're all paying 75 bucks a head for the joy of listening to this whole thing so you get put into proper reality. You're all going to sign your 5% minimum CGI donation to this DMSMH Campaign. Do you realize if the missions paid for the campaign as a whole it would take you guys some 200 weeks of your current payment level? Four years. You could never afford to do it and yet just having in the phone book, "Dianetics" and "Scientology" is going to get you a bundle of public in. You're not getting more information cards from the orgs, nothing!

You're gonna get Dianetics and Scientology as a household word. And even the top PR experts available to us, who've been planning this whole thing out with targets and so forth so this thing is going to fly. And if you look at it Battlefield Earth has been released on the same pattern as the early 1950s when LRH was a popular writer with DMSMH released right, right on the heels of it and that put it right on the best seller list. And right now Battlefield Earth is selling out and selling out and selling out again. So we got a tremendous popularity thing going and you guys are getting a gift at 5% of CGI -- it's a total gift. So if I hear one person in this room who is not coughing up 5% as a minimum you've got an investigation coming your way

CMDR. WENDELL
REYNOLDS, INTER-
NATIONAL FINANCE
DICTATOR (cont'd):

because you got other crimes in your mission.
Questions on that?

Do you guys have an unreality on the rip-offs that are going from orgs? Do you have some unreality about Academies being delivered in missions? Academy Levels?

Any unreality about people who have gone Clear being kept or re-reged in the mission? There's one example of a person being reged for 52 intensives after going Clear in a mission.

Do you have any idea about the penalties for taking public off the orgs' lines - it's \$10,000 a head per policy. If you rip-off a staff member or have a staff member working in your mission at the same time he's employed by an org you pay for the entirety of his training/processing plus a \$2,000 fine. And that will all be enforced in addition on the mission in addition to any individual penalties leveled in a criminal nature. Is that all real clear? Okay.

We're talking PT now. Whatever you had going in the past is whatever you had going in the past. Lines drawn right here and right now. You guys are going to all write up your O/Ws tonight. Before you leave and you'll get meter checked. And I want everybody straight -- on yourselves and anybody else that you know. And if you don't come clean and I find out something later on that P/L is enforced. You are guilty of anything that you didn't report on. Right per that P/L. We talk the same language?

(Uh-huh.)

Any questions? Anyone want to leave? Okay.

If we will pull this thing together and get all these nuts off the line and actually do Dianetics and Scientology you can go anyplace you want to go. Right now there is so much criminality floating through this mission network I don't want to hear about it. IF you come clean we'll work out some reparations for all the rip-offs that you've done in the past and straighten the record. If you don't want to come clean, forget it. If you've done stuff in the past and you come clean now we'll give you the benefit of the doubt. We'll assume that you weren't hatted or you were misdirected or something else. You don't come clean tonight and I find out something after this, man, you've had it. That's all I have to say.

(Applause.)

Just a recap on everybody, because that was actually the last speaker. As you basically see we have a new corporate structure, we have a new organization. There's flowlines. There's new management. The infiltration days are over, the bribe days are over, the

AUDIENCE:

CMDR. WENDELL
REYNOLDS, INTER-
NATIONAL FINANCE
DICTATOR:

AUDIENCE:

CMDR. DAVID
MISCAVIGE:

CMDR. DAVID
MISCAVIGE (cont'd):

anything-goes days are over. What goes is standard policy. What goes is people flowing through the bottom of the bridge up the bridge. What goes is no rip-offs. I was in San Francisco Org today and a Mission Holder from Seattle came in to get an org pc. Well that person's paying \$10,000 and her mission status is being reviewed. Now I don't want to close down a bunch of missions.

But I will tell you something -- somebody who's going to rip off orgs and not apply policy, then obviously they're not about to apply Scientology tech either. So therefore I don't trust them and we're better off without them.

Just so you know where we stand. Now we can all get along easily if policy is applied. We're not talking about anything else. We're not giving any whimsical rules. Because of all out-ethics that's gone on in the last two years specific things like the Mission Holders "Mutiny".

That's just not going to go on anymore. That hurts everybody and it's at an end. So we had to get real tough and we've gotten tough. Our organization will not be violated. Neither legally or ecclesiastically.

Standard Tech, Standard Policy, that's the name of the game. And because we mean business we're going to go legal. We will prosecute. If you take a look at it any person who starts to take rip-offs, should've been getting people into the missions or into the orgs and by actually getting a lot of missions and orgs functioning and everybody would be prosperous. The rip-off artist makes everyone suffer and work harder. It's an everybody loses situation. So what we've done is set up everything so it's an everybody wins situation. The rules of the game are laid out. There's nothing else, there are no arbitraries. But as I stated, there will be no rip-offs or out-tech tolerated. Those are the rules. And they will be stuck to.

There's no more "do whatever you want", "we don't care as long as your stats are up". That's nuts. And in every case we investigated where these upstats were going on in the face of out-tech and off-policy, we find that they were false stats. So apply policy, apply tech, apply the flowlines of the bridge and there's policy on that for missions, and we all win. Okay?

Next thing is we have some MAAs over here; they're going to pass out some paper -- as Mr. Reynolds pointed out, we're going to have O/W write-ups and the \$75 collection to pay for this convention and Knowledge Reports. Standard Knowledge Reports. So right now is the time to come clean and get a fresh start. Everybody in agreement?

AUDIENCE:

Yup (agrees).

CMDR. DAVID
MISCAVIGE:

Okay. Pass them out.

(Sounds of paper shuffling and talking in the audience.)

(Break for O/W write-ups and Knowledge Reports.)

(Recommencement of conference.)

CMDR. WENDELL
REYNOLDS:

Now the procedure which we have worked out for how to square the books on this whole thing is that we are going to record every point of inflow from organizations into missions. And you will do that by returning to your missions and require O/W write ups and knowledge reports from all your staff to fully document all the points of inflow into the mission from orgs. And that will be pcs, students, staff, mailing lists, people reged for mission services beyond the point they should have gone to a higher org, Academy levels, anything else which has been delivered in violation of the intention of missions and that is intended to represent accurately the entire overt on orgs of the mission since the day it started. And we are going to start with the COSMOD Missions and the Stevens Creek and we are going to send teams in who will be doing meter checks at the end of all the write-ups and verifying the estimation.

Do you have a question on this, do you get what I am saying?

(Person raises hand.)

YEAH?

CMDR. WENDELL
REYNOLDS:

PERSON:

I don't quite understand what you mean about, I understand but I'm not quite getting the out-flow, inflow into the missions from the org.

CMDR. WENDELL
REYNOLDS:

Inflow to the mission from the orgs.

PERSON:

From the orgs.

CMDR. WENDELL
REYNOLDS:

Yeah. The flow, the flow from missions is up the Bridge to orgs. OK.

PERSON:

Everything which flows from the org down to the mission is an overt on the flow on the Bridge.

CMDR. WENDELL
REYNOLDS:

I got it.

And that is essentially what we are addressing here. What we are trying to do is erase an engram which has been in place for some time and that is going to take more then just cleaning up your own universe. It is going to take some physical universe action.

PERSON:

CMDR. WENDELL
REYNOLDS:

Right.

There's factually a liability condition that exists. And in some cases some of the missions it is going to appear perhaps insurmountable and yet you will find that by actually handling the overt you will then unleash the potential of the mission to start to flow up the Bridge.

If we don't handle that, as an overt and as an engram we are going to be stuck with the wrong condition on the Bridge and it will not flow.

So the intention is, all the backlog off the line. Clean the slate and once we've got the full estimation we will work out with the individual Mission Holder how that's going to be repaid to the orgs. Because in some cases it is going to be in the millions of dollars like COSMOD, it is going to be in the millions margin.

Stevens Creek, we already know: it is $\frac{1}{2}$ of a million over the last couple of months of people who were reged after they went Dianetic Clear. That is all overt. That's all going to get cleaned up.

On the teams that will be going in; will be to verify by meter check the accuracy of what's going on and to do physical universe inspections of the actual records, the past files, the pc folders and so forth of the org. I mean I'm sorry for the mission. And we will get all that as straight as it can be gotten. And we will reorient these flows up the line.

So that is the basic orientation. We will start with those two, which are the biggest chains and then we are going to go around the rest of the US and then we are going to go to the NON US.

We are just going to end this whole game once and for good and even the score. And then from there, it is all up line.

My postulate is that everybody comes fully clean, if you have mission staff. Like some of the Mission Holders said that they don't know what went on in the mission. Well that is inexcusable. You are still responsible for what went on there and it will be treated in that vein.

So, you are to go back and find out from your staff what actually has been going on and the entirety of what has been going on all the way back to day one of the mission. I want to just clean that up.

So we will send in some teams who are outside and won't have mutual rudiments with the mission to assist on the meter checks on that. And if you have staff that won't come clean they will be ordered to Flag for sec check either at the mission expense or at their own expense at preferential rates. And they will get a full sec check until the actual scene is brought out. Brought out into the open.

CMDR. WENDELL
REYNOLDS (cont'd):

You will probably find that you have attracted certain staff who are there for the wrong reasons, who will have to be sorted out and that is just the way it goes.

But that is the basic game plan and that is the basic way that we can win on this thing.

So, do I have your agreement on that?

AUDIENCE:

YES.

CMDR. WENDELL
REYNOLDS:

OKAY. All your knowledge reports and so forth are to be sent to Int Finance Ethics Officer at Flag and you should keep a copy of everything in the mission so that when the mission comes in to do the verifications and meter checks and so forth they will have the raw data as well as having a full data bank at Flag.

And I am sure we will get various and sundry things to be cleaned up and the intention here is to clean it up.

We don't necessarily like to declare people or handle ethics except where it is necessary for the "greatest good for the greatest number of dynamics" in which case we do it wholeheartedly.

And you can just tell your Mission staff and I am sure that you have got the message by now yourselves, that we are not goofing around. That this planet is a mud bowl and it is going to stay that way unless we fix it. And the determination I believe is appearing in this room to make that actually happen on the organizational pattern as laid out by LRH.

So having your full support on that will be of assistance. If we don't have it it is going to be too bad for you.

So go back and give that message to your Mission staff and let's get this thing straightened out and moving.

What you say?

AUDIENCE:

YES!

CMDR. WENDELL
REYNOLDS:

Okay. Thank you.

AUDIENCE:

(Applause.)

CAPT. GUILLAUME
LESEVRE:

All right. So you've got your quotas. You guys all written down your quotas.

AUDIENCE:

Yeah.

CAPT. GUILLAUME
LESEVRE:

Pcs and students to orgs. Very good.

Now. Now you've got to double those quotas of new people you are going to start on services. Just take those quotas, double them for this week on people you are going to start in the mission for the first time on services.

CAPT. GUILLAUME
LESEVRE (cont'd):

Because I tell you something. I've told it to you before, you are going to have to start to reaching out for the new public.

All right.

Now on those quotas, the public, the people you are going to send back to the orgs that belong there. You know. People are gotten there this year starting in the orgs that you are going to have to, this week, re-send back to the orgs. They don't count on those quotas. Is that clear?

AUDIENCE:

Yes.

CAPT. GUILLAUME
LESEVRE:

The pcs and students that you are going to send those orgs have never seen them. All right.

Now, reading some of these O/Ws, we see that we've got a whole bunch of cycles. You know. You've got a lot of cycles to handle now. To clean up that stuff. You know, Academy levels sold, ah people over-reged after Dianetic Clear and things like that. You are going to have to start to handle that tomorrow. Right away.

You should, when you go back, you should make a list, you know, and write down all those cycles, to start cleaning them up and ending them.

I mean, those teams that are going to come to the Missions, you know, your missions are going to be paying for it.

Now if you start to handle your own scene, you know, fast, this week, you will be saving some money as well.

CMDR. WENDELL
REYNOLDS:

The price for the missions coming in to do the verifications will be \$15,000 a day. You can save yourselves a lot of time and expense if you just get your whole act together. You can either meter check your staff in advance if you want to whatever you want to do. So the missions can come in and just verify the whole thing and as much preps as you do is the faster it is going to happen. If they are there for a long time, it will be expensive. If they're not it won't be as expensive. They'll be paid at the start of each day that they are there.

CAPT. GUILLAUME
LESEVRE:

Good.

If I were you, I'd start getting going on that right tomorrow, okay?

AUDIENCE:

Yes.

CAPT. GUILLAUME
LESEVRE:

The other thing I want to say is, I want to stress again -- this is the moment when we're going to find out who is with us and who is not with us.

I can tell you something. I had so much troubles with missions in the past that in one country in Europe I forbid that there were any missions. It was forbidden in that country. That was

CAPT. GUILLAUME
LESEVRE (cont'd):

Italy. Now that country is a country that is expanding the most, where Scientology expanded the fastest on the whole planet.

No missions, not one.

I'm not saying that there shouldn't be missions. That is just to show we don't owe anything to the world. We don't have to have anybody. Is that clear?

AUDIENCE:

Yes.

CAPT. GUILLAUME
LESEVRE:

Okay. Now you have double quotas on the pcs and students that you are going to send to orgs of new people you are going to start on basic services, right?

N.B.

Now when you come back, I suggest definitely that you get rid of all those Ruth Minshull and Peter Gillham and other publications and you just get on LRH books. Just go down in your reception in your bookstore and just get those other books out of there.

Because what do you want to do? You want to get on Source and you want to have a stand out intro line. Really stand out intro line. Now in order to do that, you got to get the projector. You got to show the LRH Film, like the Freedom Film and then you got to deliver your Book One auditing and train Book One auditors.

That is what is needed and wanted. And that is how you are going to do it.

All right. Now before you leave, outside they have this table with two persons from the Golden Era Studios and each one of you is going to get a projector. It is 2,000 dollars. Each one of you is going to get a projector. How many of you guys have got a projector in his mission now?

Okay. Those that don't have a projector, get a projector before you leave from here. Then you are going to get the Freedom Film and you are going to start showing that.

Okay. We are going to get that whole scene completely stand (stamped) out and on policy and on Source. Every single last bit of it.
Okay?

AUDIENCE:

Right/Great.

CAPT. GUILLAUME
LESEVRE:

Very good.

AUDIENCE:

Anyone of you been using such a thing called the Counsellor Ad?

CAPT. GUILLAUME
LESEVRE:

Yes.

AUDIENCE:

Who has been using that?

(Raise of hands.)

CAPT. GUILLAUME
LESEVRE:

All right. That Ad shouldn't be used. Okay?
It has been misused. And it's misleading.
Okay?

People come in. They come for a certain reason,
and then they find out that is not what is
being offered to them. Don't use that Ad.

Getting standard new public procurement actions.
You can Body routing. You distribute fliers.
PSMs. Show them films, Intro Lectures, Book
One auditing. Cancel that Ad now. Cancel it.
It's no good.

SMI will be giving you a new ad to put up.
But in the meanwhile don't wait for it. Cancel
that ad right now and get on all the other pro-
curement actions. Okay?

AUDIENCE:

Okay/Yeah.

CAPT. GUILLAUME
LESEVRE:

All right.

AUDIENCE:

(Applause.)

CMDR. DAVID
MISCAVIGE:

Okay. The last two things.

One is, I don't know, I guess you guys will be
talking to other Mission Holders once you
leave. Correct?

AUDIENCE:

Right.

CMDR. DAVID
MISCAVIGE:

I believe all the Mission Holders in the US
were called to come to this meeting and several
didn't. You might want to just tell them one
thing.

Just a message. They will be getting the
message anyway, but you will probably be quicker.
I know how fast the rumor lines or the phone
lines are.

We have run across something recently whereby
there's a little technique of make wrong when
someone tries to put in ethics. It's actually
a suppressive make wrong.

It goes "If you put in ethics, we're going to
crash our stats to show you that you can't put
our ethics in and that is a wrong indication".

Tell them we don't buy it. If it happens they
will get a mission. A Sea Org mission to their
mission. Okay? Just a little message.

Last thing I wanted to mention is, now is the
chance to straighten out everything. It really
is a chance to start on a new road up, fresh.
It is only going to happen with all these
cycles which Mr. Reynolds and the ED Int spoke
about and if you do that, you are on the winning
team. We are winning legally. We are winning
statistically. And Scientology is going up.

I just want to let you know that because that is
the plus point of it all. And we will win in the
end. Okay?

AUDIENCE:

Right.

CORPORATE AFFAIRS DIRECTOR
W/O SPURLOCK'S TALK

Chart 1

Church of Scientology
of California
(CSO)

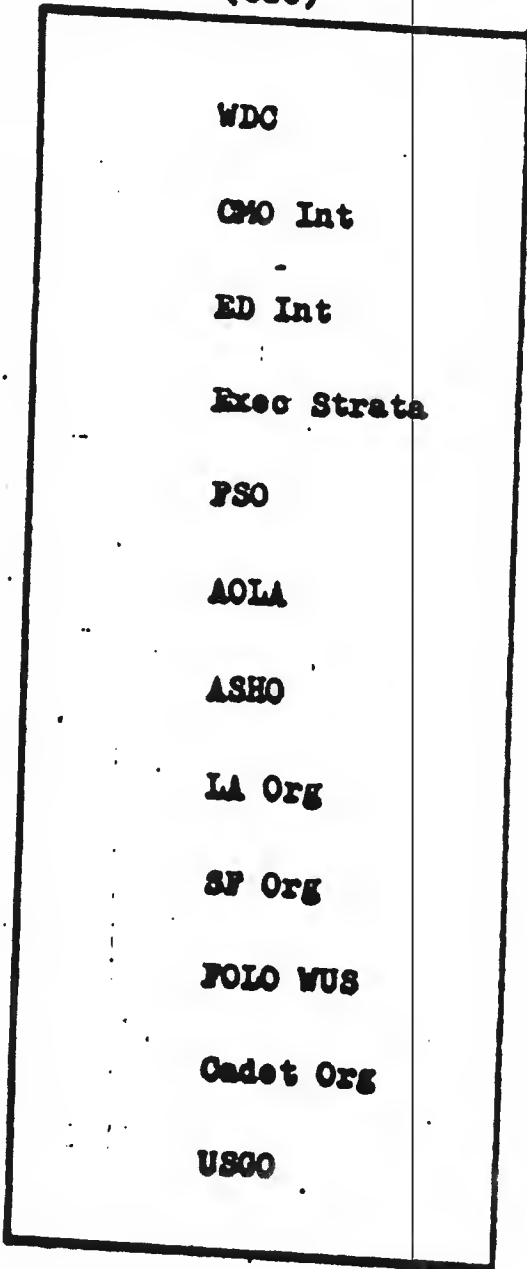

ORGS

Mother
Church

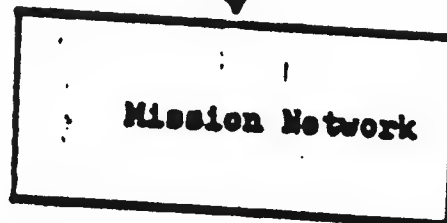
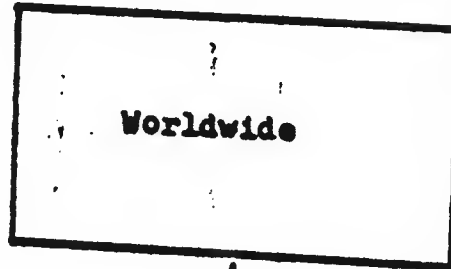

(This chart is referred to on page 4 of the transcript.)

CORPORATE AFFAIRS DIRECTOR

W/O SPURLOCK'S TALK

Chart 2

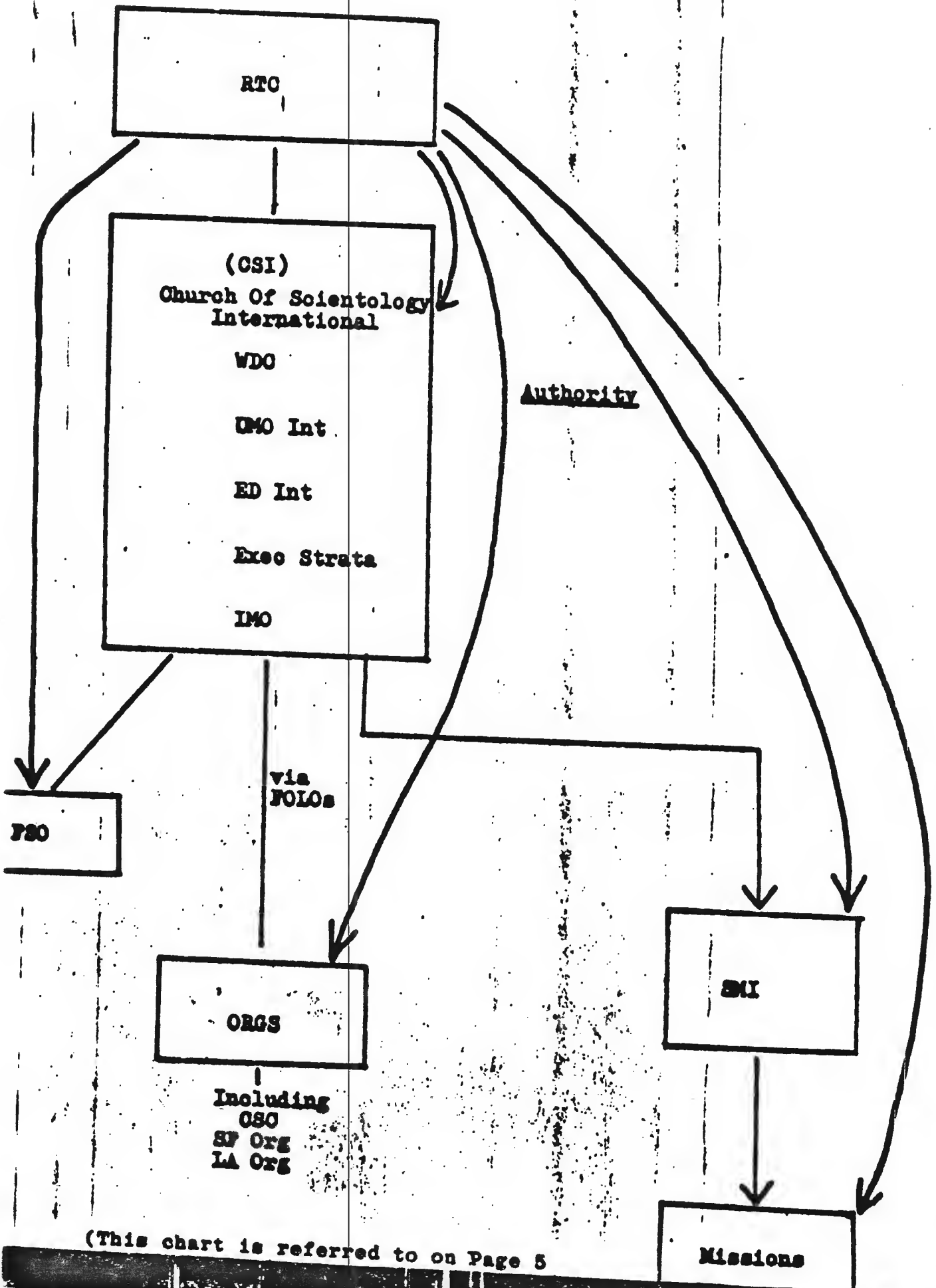

(This chart is referred to on Page 5

CAPTAIN MARC YAGER'S TALK

Chart 3

FLOW UP THE BRIDGE

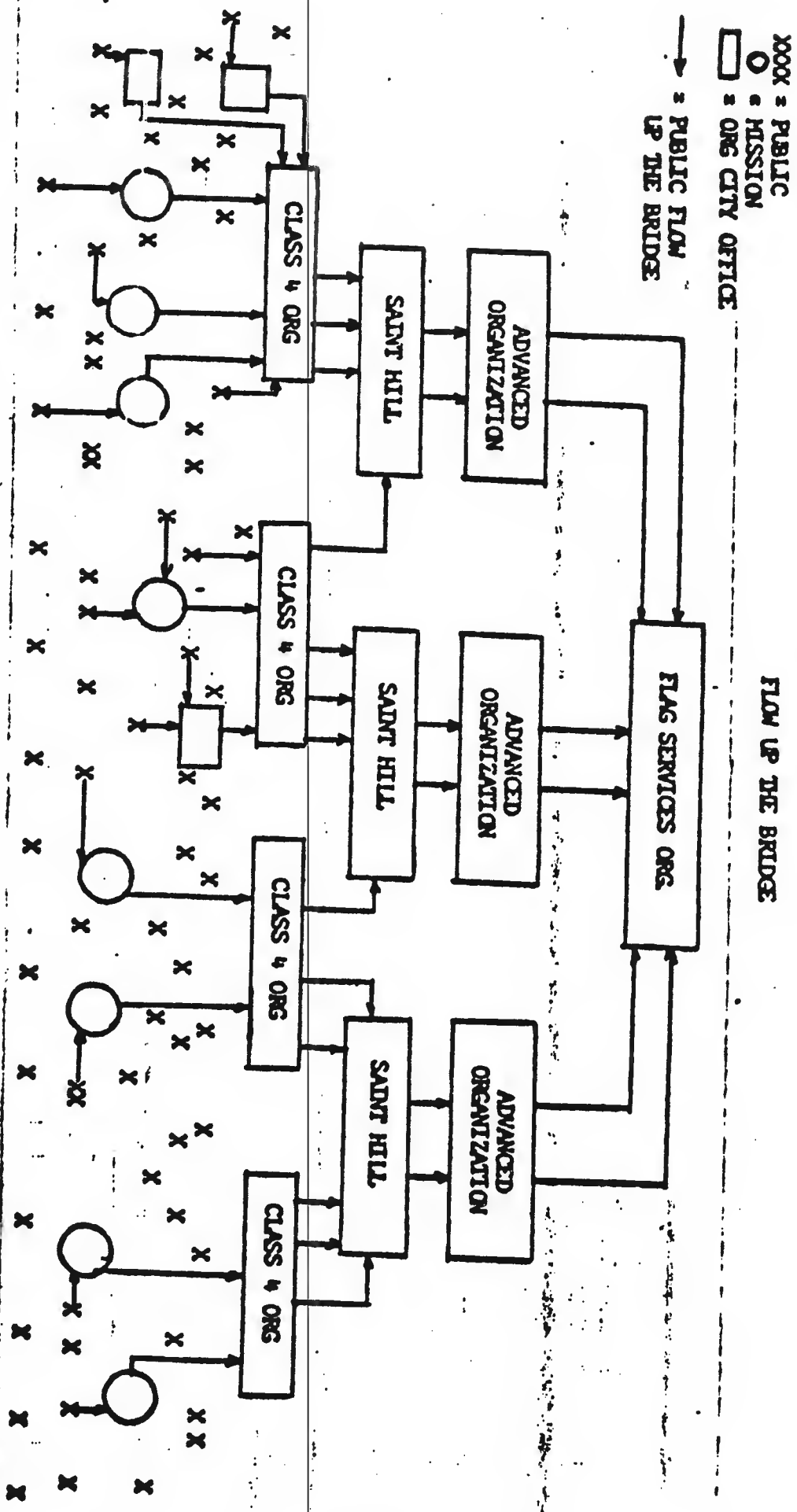

(This chart is referred to on page 22 of the transcript.)